

# VERTICADE™

Narrow design is perfect for tight configurations



12'W x 36'H  
Sheeting Panel

- Compact stacking, feet fold for transport and storage
- Quick set-up
  - spring loaded feet quickly release for placement
- Lies flat when hit
- Replaceable sheeting panels
  - recessed panels are removable, just clip on new panels
- Anti-skid pads on feet reduce movement in work zones
- 7 lb. feet - filled with silica sand
  - optional ballast boots snap on feet adding 20 lbs. each
- Molded-in light receptacle for "D" cell battery lights
- Available in white
- NCHRP-350 Accepted, Meets MUTCD Standards



Lies flat when hit,  
reducing damage to unit and vehicle



Distributed by



1-800-236-0112  
www.tapconet.com

5100 West Brown Deer Road  
Brown Deer, WI 53223

Contract Holder  
GS-07F-5924R  
GS-07F-0234U

U.S. COMMUNITIES  
GOVERNMENT PURCHASING ALLIANCE  
Supplier Partner

TF029 Rev. 1

# VERTICADE™

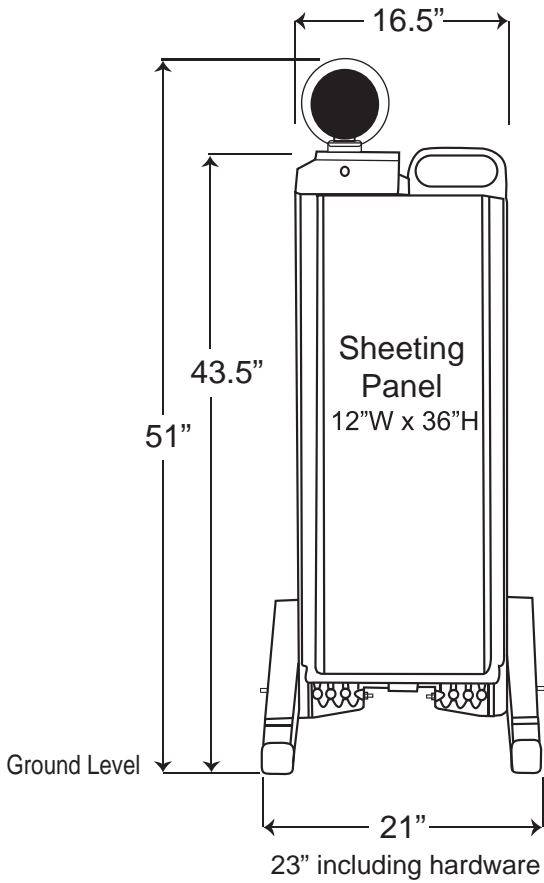

Specs	
Composition	High Density Polyethylene
Dimensions	43.5"H x 21"W x 3"D
Colors	White
Weight	27 lbs.
Retroreflective Sheeting	Available in all grades in white and orange

## Ballast Boot

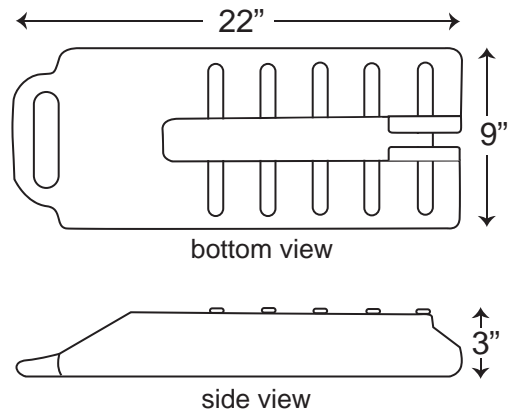

Ballast Boots weigh 20 lbs. each when filled with sand.

Verticade with two boots - 67 lbs.

Ballast Boot

Carry Handle



HDPE

MADE IN THE USA

Distributed by



1-800-236-0112  
www.tapconet.com

5100 West Brown Deer Road  
Brown Deer, WI 53223

GSA Contract Holder  
GS-07F-5924R  
GS-07F-0234U

U.S. COMMUNITIES  
GOVERNMENT PURCHASING ALLIANCE  
Supplier Partner