

IN GROUND MOUNT (IG)

SECTION VIEWS

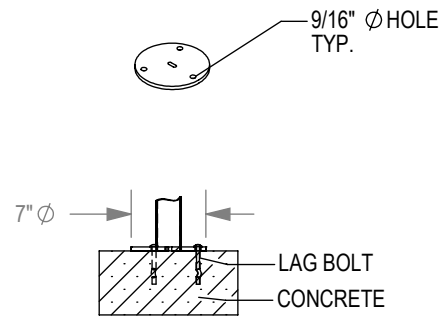

SURFACE FLANGE MOUNT (SF)

CHECK DESIRED MOUNT

PRODUCT: PAR-2-SF(IG)
 DESCRIPTION: POST AND RING BIKE RACK WITH FLAT CAP, TUBE STEEL ARMS
 2 BIKE, SURFACE OR IN GROUND MOUNT

DATE: 9-16-13
 ENG: SMC

CONFIDENTIAL DRAWING AND INFORMATION IS NOT TO BE COPIED OR DISCLOSED TO OTHERS WITHOUT THE CONSENT OF GRABER MANUFACTURING, INC. SPECIFICATIONS ARE SUBJECT TO CHANGE WITHOUT NOTICE.

- NOTES:
1. INSTALL BIKE RACKS ACCORDING TO MANUFACTURER'S SPECIFICATIONS.
 2. CONSULTANT TO SELECT COLOR (FINISH), SEE MANUFACTURER'S SPECIFICATIONS.
 3. SEE SITE PLAN FOR LOCATION OR CONSULT OWNER.

Distributed by



5100 West Brown Deer Road
 Brown Deer, WI 53208

1-800-236-0112
 www.tapconet.com

