

Traffic Logix®

# SafePace® 475 Radar Speed Signs

Product Specifications Version 1.0

---

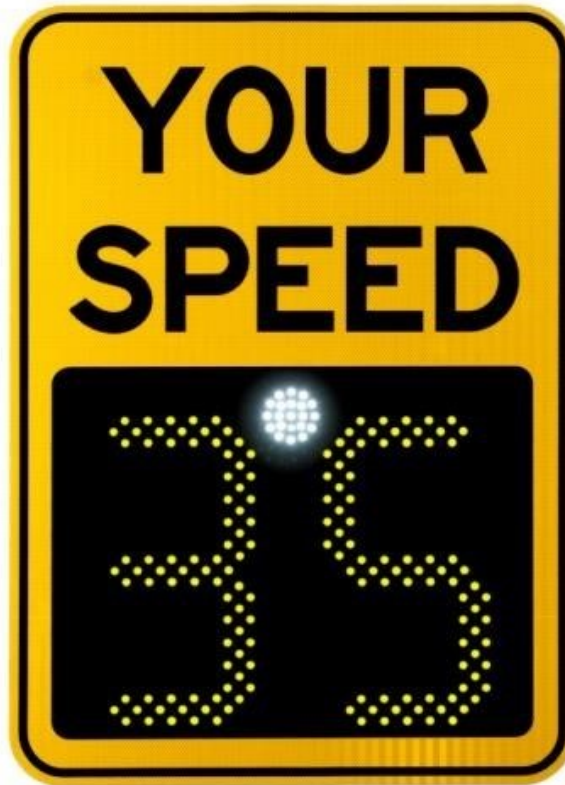

---

**\*ALL SPECIFICATIONS SUBJECT TO CHANGE WITHOUT NOTICE**

Distributed by



1-800-236-0112  
www.tapconet.com

5100 West Brown Deer Road  
Brown Deer, WI 53223

 Contract Holder  
GS-07F-5924R  
GS-07F-0234U

 U.S. COMMUNITIES  
GOVERNMENT PURCHASING ALLIANCE  
Supplier Partner

# Table of Contents

Dimensions.....	3
Sign Weight .....	3
Accessories .....	3
Technical Specifications .....	4
Power .....	4
Radar .....	4
Display .....	4
Enclosure .....	5
Mounting Options .....	5
Communication.....	5
Programming.....	5
Data Collection and Statistical Analysis & Reporting (optional feature).....	6
Solar Panel Specifications .....	7
Mechanical Data .....	7
Temperature Coefficients .....	7
Electrical Data .....	7
Warranty and Certifications.....	7
Dimensions.....	8
Universal Mounting Bracket System.....	9
Warranty .....	10
Warranty Replacement Procedure .....	11

---

**\*ALL SPECIFICATIONS SUBJECT TO CHANGE WITHOUT NOTICE**

## Dimensions

- Digit: 18.0"(h) × 9.6"(w), 112 LEDs per digit
- Text:
  - Full Size: Letters 6.0"(h) spell "YOUR SPEED" fixed message, 2 lines
- Unit alone: 24.6"(h) × 29.5"(w) × 3.5"(d)
- Unit with "YOUR SPEED" sign mounted:
  - Full Size: 42"(h) × 31.5"(w) × 3.5"(d)

## Sign Weight

- AC Powered Model: 42 lbs
- 4 Cell Battery Powered Model (3 batteries): 53 lbs
- Solar Powered Model: 42 lbs (does not include solar panel or solar panel bracket)

## Accessories

- 4 Cell Lithium Ion Battery: 4 lbs
- Universal Mounting Bracket System
  - Sign Bracket: 2 lbs
  - Pole Bracket: 5 lbs

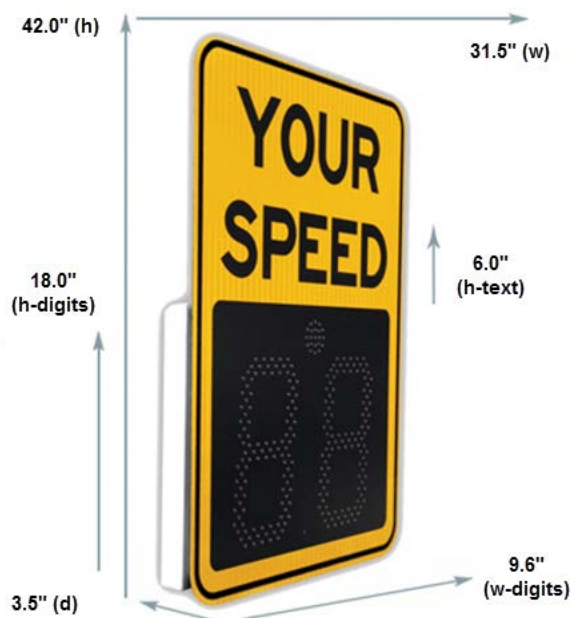

**\*ALL SPECIFICATIONS SUBJECT TO CHANGE WITHOUT NOTICE**

Distributed by **TAPCO**<sup>®</sup> 1-800-236-0112 5100 West Brown Deer Road  
www.tapconet.com Brown Deer, WI 53223

**GSA** Contract Holder  
GS-07F-5924R  
GS-07F-0234U

**U.S. COMMUNITIES**  
GOVERNMENT PURCHASING ALLIANCE  
Supplier Partner

**Ver. 1.0**

## Technical Specifications

- Miles Per Hour (mph) or Kilometers Per Hour (km/h)
- Aluminum protective cover: 0.1875" (d)
- Yellow or white High-Intensity prismatic reflective sheeting on the sign face with black colored text
- MUTCD approved colors and format
- Operating Temperatures F (C): -40° (-40°) to 185° (85°)
- Conformal coating on all circuit boards

### Power

- Power input:
  - AC 100~240 V AC
  - 12 V DC
  - Built in ambient light sensing and automatic brightness control
  - Wireless battery charge monitor
- Power Options
  - AC power input: 100~240 V AC
  - DC power input: 12 V DC
  - Solar power: 90 W solar panel

### Radar

- Internal Radar: Doppler (FCC approved)
- Radar RF out: 5 mW maximum
- Radar f-center: 24.125 GHz center +/-25 MHz
- Pickup distance: Up to 1,200 feet (366 m)
- Beam angle: 11° × 11°
- Beam polarization: Linear

### Display

- LEDs 245:
  - Digits: 224 Amber, 23°, 5 mm, luminous Intensity (5680 – 8200 mcd/LED)
  - Speed Violator Strobe: 21 White, 15°, 5 mm , luminous intensity (28,150 mcd/LED)
- Optical lenses: 245 lenses
- Ambient light sensor and automatic brightness adjustment

---

**\*ALL SPECIFICATIONS SUBJECT TO CHANGE WITHOUT NOTICE**

## Enclosure

- 12 gauge aluminum, flat black powder coated front for reduced glare and maximum contrast; light gray powder coated body to minimize heat absorption
- Weatherproof, NEMA 4X-12, IP65 level compliant
- Non-sealed and ventilated

## Mounting Options

- Banding brackets (standard)
- Universal Mounting Bracket System
  - Universal mounting options: circular, square and telspar poles
  - Theft resistant
  - Promotes sign portability: sign locks into mounting bracket with a turn of a key

## Communication

- Bluetooth 4.0
- Wi-Fi (optional)



## Programming

- SafePace® Pro management software
- 24/7 365 day unlimited programming and scheduling
- Display Settings:
  - Display On/Stealth Modes (In Stealth Mode, speed is not displayed but data is collected)
  - Display Minimum Speed, Display Maximum Speed
  - Flashing Digit Speed Threshold (digits flash above selected speed)
  - Speed Violator Strobe (pulsing strobe flashes with digits or alone above Display Maximum Speed)



---

**\*ALL SPECIFICATIONS SUBJECT TO CHANGE WITHOUT NOTICE**

Distributed by  **TAPCO**®

1-800-236-0112  
www.tapconet.com

5100 West Brown Deer Road  
Brown Deer, WI 53223

 Contract Holder  
GS-07F-5924R  
GS-07F-0234U

 U.S. COMMUNITIES  
GOVERNMENT PURCHASING ALLIANCE  
Supplier Partner

**Ver. 1.0**

## Data Collection and Statistical Analysis & Reporting (optional feature)

- Traffic data collected and stored by location
- Stealth Mode (capture baseline traffic data with speed display off)
- Download through wireless connection
- Statistical Reporting & Charts
  - Summary Reports
  - Weekly Reports
  - Period Comparison Reports
  - Full custom reports and charts
  - Reporting Parameters:
    - Average Vehicle Count
    - Total Vehicle Count
    - Average Speed
    - Average Number of Speed Violations
    - Total Number of Speed Violations
  - Other Features:
    - Minimum and Maximum Speed
    - 85% Speed
    - Counters by Speed Bins
    - 5 MPH Bin Resolution
    - Reports print directly or can be exported into CSV format, MS Excel, Adobe Acrobat PDF and HTML
    - Charts may be printed directly or converted into Adobe Acrobat PDF and picture formats



---

**\*ALL SPECIFICATIONS SUBJECT TO CHANGE WITHOUT NOTICE**

Distributed by



1-800-236-0112  
www.tapconet.com

5100 West Brown Deer Road  
Brown Deer, WI 53223

 Contract Holder  
GS-07F-5924R  
GS-07F-0234U

 U.S. COMMUNITIES  
GOVERNMENT PURCHASING ALLIANCE  
Supplier Partner

**Ver. 1.0**

## Solar Panel Specifications

Model: GMA Solar Panel GMA90

### Mechanical Data

- Solar Cells: 36 Monocrystalline (156 mm × 156 mm)
- Front Glass: 3.2 Tempered
- Junction Box: Certified Junction Box
- Output Cables: 1000 mm (length with connectors)
- Frame: Anodized Aluminum
- Weight: 8 kg
- Dimensions: 890 mm × 665 mm × 35 mm

### Temperature Coefficients

- NOCT: 45 +/- 2° C
- Operating Temperature: -40° C to +95° C
- Voltage Temperature Coefficient (Voc): -0.36%
- Current Temperature Coefficient (Isc): +0.033%
- Power Temperature Coefficient (Pmpp): +0.44%
- Minimum Power Tolerance: -0%~/+3%

### Electrical Data

- Nominal Peak Power (Wp): 90 W
- Nominal Voltage (Vmp): 17.2 V DC
- Nominal Current (Imp): 5.23 A
- Open Circuit Voltage (Voc): 21.6 V DC
- Short Circuit Current (Isc): 5.87 A
- Operating Temperature: -40° C to +85° C
- Maximum System Voltage: 600 V DC (UL), 1000 V DC (IEC)
- STC: 1000 W/m<sup>2</sup>, 25° C, AM = 1.5

### Warranty and Certifications

- Warranty: 12 Year Workmanship, 12 Year 90%, 25 Year 80% Power Warranty
- Certification: UL 1730, IEC 61215, IEC 61730, CE, cETLus



**\*ALL SPECIFICATIONS SUBJECT TO CHANGE WITHOUT NOTICE**

Distributed by



1-800-236-0112  
www.tapconet.com

5100 West Brown Deer Road  
Brown Deer, WI 53223

 Contract Holder  
GS-07F-5924R  
GS-07F-0234U

 U.S. COMMUNITIES  
GOVERNMENT PURCHASING ALLIANCE  
Supplier Partner

## Dimensions

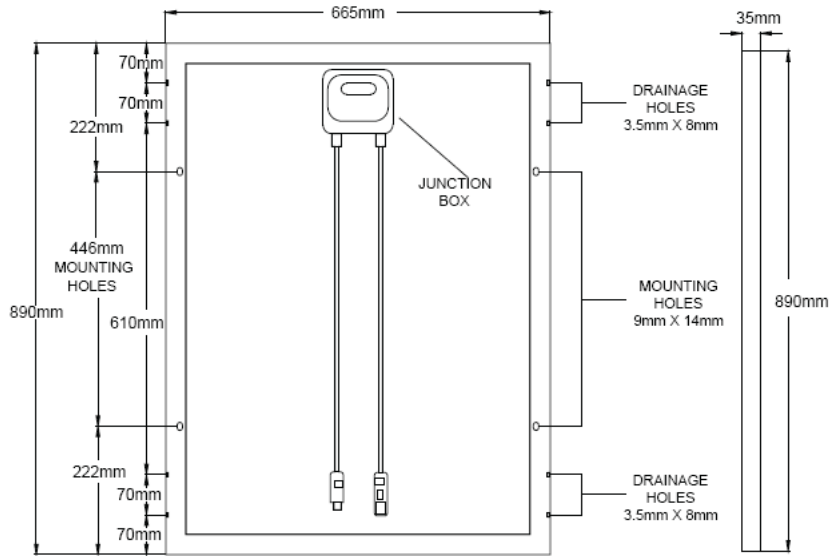

**\*ALL SPECIFICATIONS SUBJECT TO CHANGE WITHOUT NOTICE**

Distributed by



1-800-236-0112  
www.tapconet.com

5100 West Brown Deer Road  
Brown Deer, WI 53223



**Ver. 1.0**



# Universal Mounting Bracket System

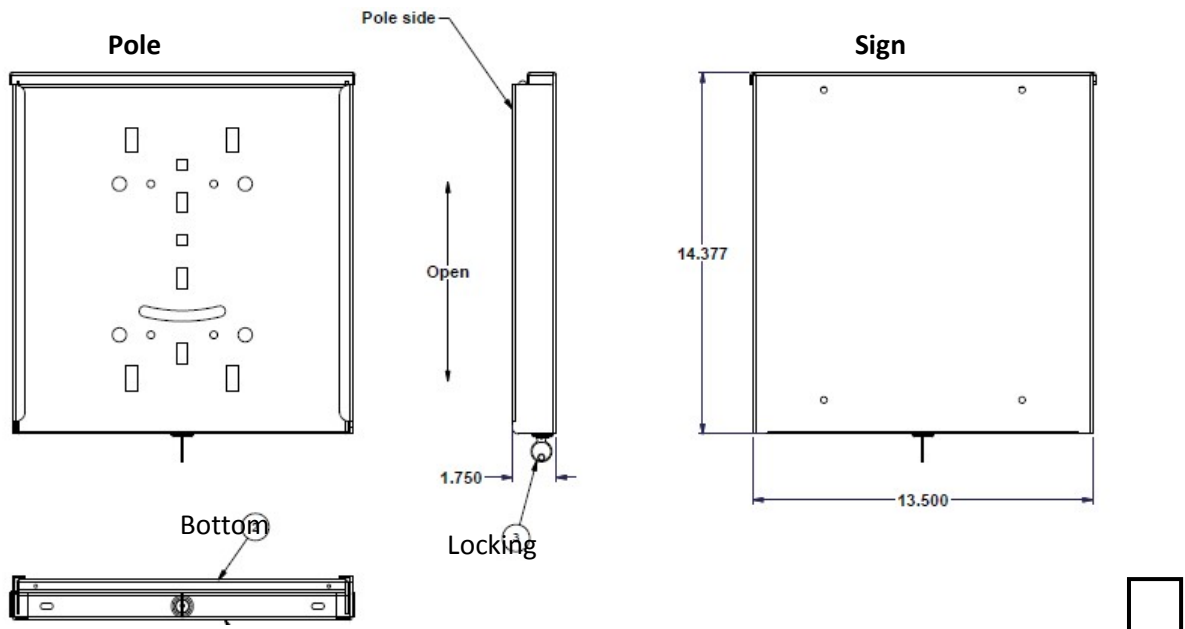

## Inside view

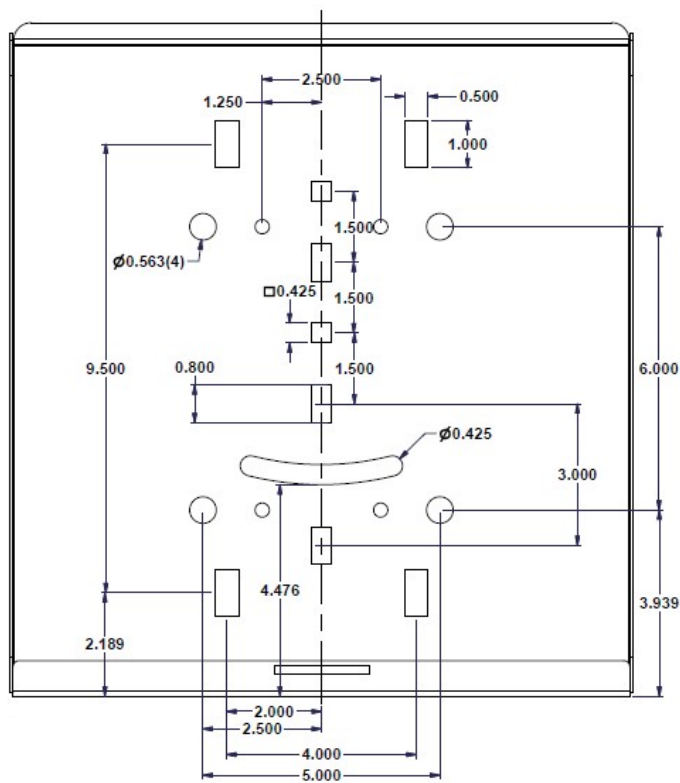

**\*ALL SPECIFICATIONS SUBJECT TO CHANGE WITHOUT NOTICE**

Distributed by **TAPCO**® 1-800-236-0112 5100 West Brown Deer Road  
[www.tapconet.com](http://www.tapconet.com) Brown Deer, WI 53223

**GSA** Contract Holder  
 GS-07F-5924R  
 GS-07F-0234U

**U.S. COMMUNITIES**  
 GOVERNMENT PURCHASING ALLIANCE  
 Supplier Partner

## Warranty

Subject to the following conditions, Traffic Logix Corporation (“Traffic Logix”) warrants that the SafePace® 475 Speed sign (the “Product”) is free from defects in materials and workmanship. This limited warranty begins on the invoice date of your purchase of the Product and extends:

- For TWO (2) calendar years on the radar sign, and
- For ONE (1) calendar year on the batteries.

This limited warranty extends only to the original purchaser of the Product when purchased either directly through Traffic Logix® or through an authorized Traffic Logix® distributor and is not assignable or transferable to any subsequent purchaser or end-user. Traffic Logix’s® obligation and liability under this warranty are expressly limited to repairing or replacing, at Traffic Logix’s® option, defective products. In no circumstances shall Traffic Logix’s® liability, whether in contract or tort, under any warranty, in negligence, or otherwise, exceed the amount of the purchase price of the product. Traffic Logix® shall not be liable for special, indirect, or consequential damages of any kind. This warranty does not cover damages resulting from normal wear and tear, incorrect installation or operation, use other than for the product’s intended purposes, vandalism, and extraordinary environmental circumstances. Traffic Logix® reserves the right to charge for these damages to the product at rates normally charged for repairing such products not covered under this warranty. Damages resulting from any physical changes or alterations made to the product other than Traffic Logix® will render this warranty **VOID**. Using any parts or accessories not supplied or approved by Traffic Logix®, such as battery chargers, will further render the warranty **VOID**.

Traffic Logix® neither assumes, nor authorizes any person to assume for it, any other liability in connection with the sale of the Product, and there are no agreements or warranties collateral to or affecting this limited warranty.

**THE LIMITED WARRANTY SET FORTH IN THIS AGREEMENT IS THE EXCLUSIVE AND SOLE WARRANTY APPLICABLE TO THIS PURCHASE. ALL OTHER WARRANTIES, EXPRESS OR IMPLIED, INCLUDING, BUT NOT LIMITED TO THE IMPLIED WARRANTY OF MERCHANTABILITY AND THE IMPLIED WARRANTY OF FITNESS FOR A PARTICULAR PURPOSE ARE EXPRESSLY DISCLAIMED.**

Traffic Logix® does not warrant that any of its products will meet or comply with the requirements of any applicable federal, state or local safety code, law, regulation or ordinance (“Applicable Safety Laws”). Buyer acknowledges that Traffic Logix’s® products are to be used only in accordance with the attached Conditional Terms of Use and any Applicable Safety Laws. Buyer agrees that there shall be no coverage or benefits of any kind under this limited warranty if it is determined by Traffic Logix® that the Product was not installed or used in accordance with the Conditional Terms of Use or Applicable Safety

---

**\*ALL SPECIFICATIONS SUBJECT TO CHANGE WITHOUT NOTICE**

Distributed by



1-800-236-0112  
www.tapconet.com

5100 West Brown Deer Road  
Brown Deer, WI 53223

 Contract Holder  
GS-07F-5924R  
GS-07F-0234U

 U.S. COMMUNITIES  
GOVERNMENT PURCHASING ALLIANCE  
Supplier Partner

Ver. 1.0

Laws, or if the Product has been altered in any way by anyone other than Traffic Logix®, or if the Product has been subject to any misuse or accident. In addition, Buyer assumes and agrees to indemnify Traffic Logix® for all risk, liability or expense that results from any installation or use of the Product that is not in accordance with the Conditional Terms of Use or any Applicable Safety Laws.

### **Warranty Replacement Procedure**

In order to submit a claim for the repair or replacement of the Product under this limited warranty, you must do the following:

- 1) Obtain a Return Materials Authorization number by contacting Customer Support. Do not ship your defective product to Traffic Logix® prior to contacting Customer Support.
- 2) A Customer Support agent will evaluate the Product to determine if it is defective. If the product is defective, then you will need to submit your contact information, and proof of purchase (including the date of purchase), in order to obtain repair or replacement parts.
- 3) The Customer Service Agent will provide you with instructions on how to have defective parts repaired or replaced.

---

**\*ALL SPECIFICATIONS SUBJECT TO CHANGE WITHOUT NOTICE**

Distributed by



1-800-236-0112  
www.tapconet.com

5100 West Brown Deer Road  
Brown Deer, WI 53223

 Contract Holder  
GS-07F-5924R  
GS-07F-0234U

 U.S. COMMUNITIES  
GOVERNMENT PURCHASING ALLIANCE  
Supplier Partner